



HYTEC ELECTRONICS Ltd

HEAD OFFICE: 5 CRADOCK ROAD, READING, BERKS. RG2 0JT, UK
Telephone: +44 (0) 118 9757770 Fax: +44 (0)118 9757566

E-mail: sales@hytec-electronics.co.uk

**VTB8255
ANALOGUE INPUT/OUTPUT
TRANSITION BOARD**

USERS MANUAL

Document Nos.: TB8255/UTM/G/x/1

Date: 10/07/2002

Author: MRN

TABLE OF CONTENTS

1. INTRODUCTION..... 2

2. SCSI CONNECTORS..... 3

3. RESISTOR AND CAPACITOR NETWORK FOR FILTERING 5

4. PCB JUMPERS..... 5

1. INTRODUCTION

The VTB 8255 is a 6U (double height) VME rear I/O transition board, which provides connection to the 8002 Carrier Board. It routes the signals from the carrier board to three 50-way SCSI sockets via the J0 and J2 connectors of the VME backplane. The board includes sites for fitting resistors and capacitors for filtering which can be switched in via PCB jumpers. Optional on-board 5V to 12V DC-DC converters are connected to pins on the RP0/RP2 connectors to facilitate powering the plant side of isolated analogue circuits on IP boards which are mounted on the carrier board.

The signals connect to the main carrier board according to the VME64x Greenspring pinout for IP module carriers .

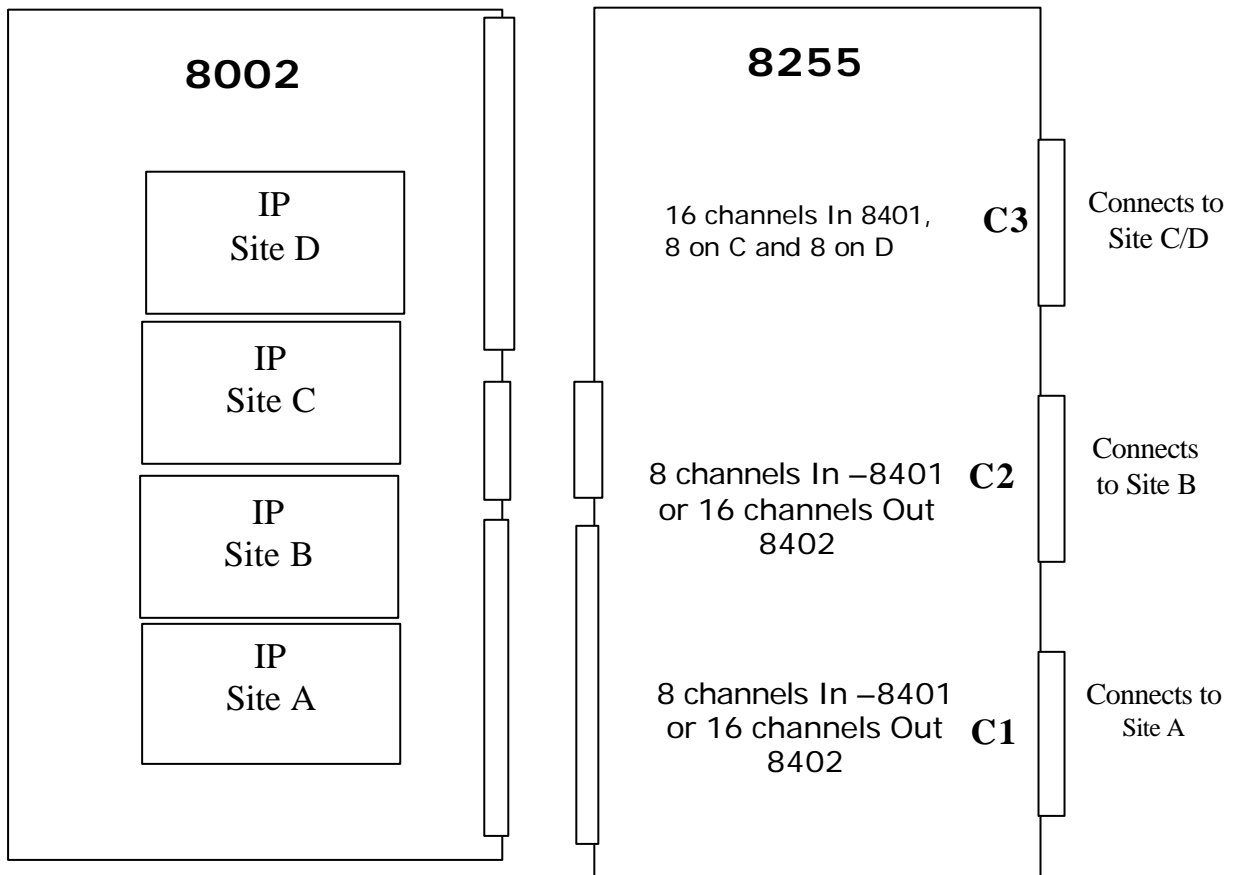



2. SCSI CONNECTORS

Connector 1 (lowest connector)	Outputs 1-16(+/-), Trigger 1(+/-), Clock1(+/-)
Connector 2	Outputs 17-32(+/-), Trigger 2(+/-), Clock2(+/-)
Connector 3 (top connector)	Inputs 33-40(+/-), Trigger3(+/-),Clock3(+/-) Inputs 41-48(+/-), Trigger4(+/-),Clock4(+/-)

I/O Connector 1 – 50 way on transition with DAC8402 on IP site A

I/O Connector 2 – 50 way on transition with DAC8402 on IP site B

Pin	Signal	Pin	Signal
1	AGND	26	Output1
2	AGND	27	Output 2
3	AGND	28	Output 3
4	AGND	29	Output 4
5	AGND	30	Output 5
6	AGND	31	Output 6
7	AGND	32	Output 7
8	AGND	33	Output 8
9	AGND	34	Output 9
10	AGND	35	Output 10
11	AGND	36	Output 11
12	AGND	37	Output 12
13	AGND	38	Output 13
14	AGND	39	Output 14
15	AGND	40	Output 15
16	AGND	41	Output 16
17		42	
18	XTRIG N	43	XTRIG P
19		44	
20	XCLK N	45	XCLK P
21		46	
22		47	
23		48	
24	AGND	49	AGND
25	AGND	50	AGND

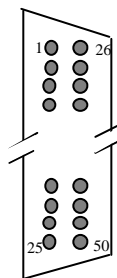



I/O Connector 3 – 50 way on transition with ADC8401 on IP sites C and D
This feeds TWO IP sites C and D on the 8002

Pin	Signal	Pin	Signal
1	C Chan 1 -	26	C Chan 1 +
2	C Chan 2 -	27	C Chan 2 +
3	C Chan 3 -	28	C Chan 3 +
4	C Chan 4 -	29	C Chan 4 +
5	C Chan 5 -	30	C Chan 5 +
6	C Chan 6 -	31	C Chan 6 +
7	C Chan 7 -	32	C Chan 7 +
8	C Chan 8 -	33	C Chan 8 +
9	D Chan 1 -	34	D Chan 1 +
10	D Chan 2 -	35	D Chan 2 +
11	D Chan 3 -	36	D Chan 3 +
12	D Chan 4 -	37	D Chan 4 +
13	D Chan 5 -	38	D Chan 5 +
14	D Chan 6 -	39	D Chan 6 +
15	D Chan 7 -	40	D Chan 7 +
16	D Chan 8 -	41	D Chan 8 +
17		42	
18	C XTRIG N	43	C XTRIG P
19	D XTRIG N	44	D XTRIG P
20	C XCLK N	45	C XCLK P
21	D XCLK N	46	D XCLK P
22		47	
23		48	
24	C AGND	49	C AGND
25	D AGND	50	D AGND

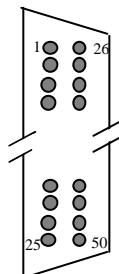

3. RESISTOR AND CAPACITOR NETWORK FOR FILTERING

The 8255 provides direct or conditioned connection set by PCB jumper to all transmit/receive I/O signals (see diagram below).

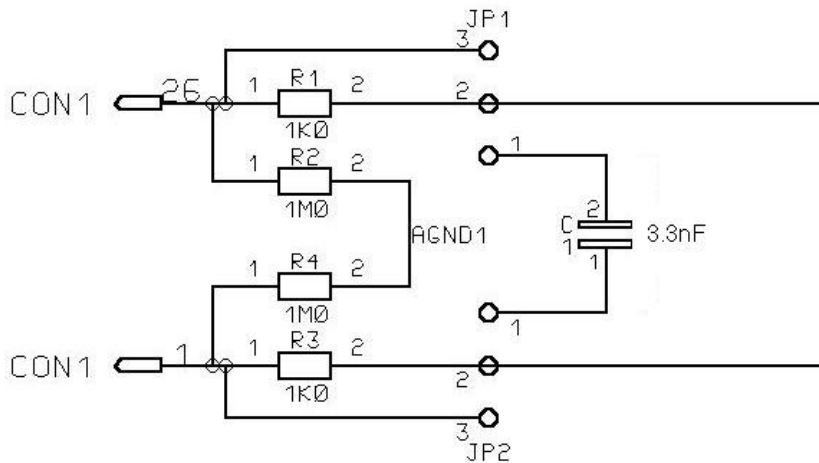

The 1K ohm resistors are matched to 0.01%

1Meg ohms are $\pm 1\%$.

No filtering components are fitted for IP sites A and B on delivered boards.

Jumpers J33 to J48 select conditioning for IP site C

Jumpers J49 to J64 select conditioning for IP site D

4. PCB JUMPERS

J49 – J64

1 and 2 made resistors and capacitors for filtering switch IN (Factory setting).

2 and 3 made straight through connection

J33 – J48

1 and 2 made resistors and capacitors for filtering switch IN (Factory setting).

2 and 3 made straight through connection .

J17 – J32

1 and 2 made resistors and capacitors for filtering switch IN.

2 and 3 made straight through connection (Factory setting).

J1 – J16

1 and 2 made resistors and capacitors for filtering switch IN.

2 and 3 made straight through connection (Factory setting).



LK1 AGND1 to GND
LK2 AGND2 to GND
LK3 AGND3 to GND
LK4 AGND4 to GND