



## **HYTEC ELECTRONICS Ltd**

**HEAD OFFICE:** 5 CRADOCK ROAD, READING, BERKS. RG2 0JT, UK  
Telephone: +44 (0) 118 9757770 Fax: +44 (0)118 9757566

E-mail: [sales@hytec-electronics.co.uk](mailto:sales@hytec-electronics.co.uk)

# **8901-T/D 16-Channel I/O DIN-Rail Mounted Terminal Board**

## **USERS MANUAL**

Document Nos.: 8904/UTM/G/x/2.0

Date: 21/07/2004

Author: AB



## CONTENTS

<b>1. INTRODUCTION .....</b>	<b>2</b>
<b>2. PRODUCT SPECIFICATIONS .....</b>	<b>3</b>
<b>3. BOARD DESCRIPTION .....</b>	<b>3</b>
<b>4. OPERATION.....</b>	<b>3</b>
<b>5. 8901-TD CONNECTION DIN-RAIL BOARD PIN-OUT .....</b>	<b>3</b>

### 1. INTRODUCTION



The Hytec 8901-T/D is a DIN-Rail mounted board which allows connection to Industry Pack I/O cards mounted on a VME64X carrier board . It connects to the IP cards via an analogue I/O transition board type 8202 or digital I/O transition boards using a 50-way SCSI cable.

- 50-way terminal connection to plant equipment.
- 50-way SCSI socket connects to transition board
- Supports one IP card or 16 channels on the 8001 Digital I/O Board
- LED indication of current flow.
- Jumpers enable LEDs to be shorted out for analogue applications
- Indication of +24V presence for use with 8301 Transition Board
- Transient voltage protection

## 2. PRODUCT SPECIFICATIONS

Size: DIN-rail mounted module approx 150x75x45mm  
 Operating temp: 0 to 45 deg C ambient  
 Power Requirements: Optional +24V indication of transition board isolated power  
 Number of channels: All 50 lines bussed  
 Number of signals: I/O 1-16, TRG, CLK, STR,STB, +24V, AGnd, plus 4 spare pairs  
 Connectors: SCSI 50-way socket for connection to transition board  
 50-way terminal screws  
 Transient protection: 26V clamp rising to 40V max @ 10A using varistorss

## 3. BOARD DESCRIPTION

The board is primarily intended to allow plant connections to VME64X board I/O using screw terminals. The signals are routed to a VME64X transition card using a 50-way twisted pair SCSI cable.

The signal pair for I/O1 connect between T26 and T1. The pair for I/O2 connect between T27 and T2 and so on up to T50 and T25. These are connected to the relevant pin numbers on the SCSI connector.

Jumpers J1-J20 can be used to short circuit the respective LEDs when input currents are not monitored i.e. the LED monitoring is disabled and the circuit is connected straight-through.

The LED which indicates the presence of +24V is over-voltage protected by a varistor.

Links LK1 and LK2 disconnect pins 25 and 50 of the SCSI.

## 4. OPERATION

### 4.1 Connection to Transition Board

Connect the unit to the SCSI socket on the transition board for the relevant carrier board site (e.g. lowest of the four connectors for an IP card plugged into site A)

### 4.2 Connection to Plant Equipment

Connect the signals to the terminals as shown in the table in section 5.

## 5. 8901-TD Connection DIN-Rail Board Pin-out

SCSI 50-way	Terminal	LED	Signal	Comment
-------------	----------	-----	--------	---------



26	26	1	I/O1 Signal	Protected pair
1	1		I/O1 Return	
27	27	2	I/O2 Signal	Protected pair
2	2		I/O2 Return	
28	28	3	I/O3 Signal	Protected pair
3	3		I/O3 Return	
29	29	4	I/O4 Signal	Protected pair
4	4		I/O4 Return	
30	30	5	I/O5 Signal	Protected pair
5	5		I/O5 Return	
31	31	6	I/O6 Signal	Protected pair
6	6		I/O6 Return	
32	32	7	I/O7 Signal	Protected pair
7	7		I/O7 Return	
33	33	8	I/O8 Signal	Protected pair
8	8		I/O8 Return	
34	34	9	I/O9 Signal	Protected pair
9	9		I/O9 Return	
35	35	10	I/O10 Signal	Protected pair
10	10		I/O10 Return	
36	36	11	I/O11 Signal	Protected pair
11	11		I/O11 Return	
37	37	12	I/O12 Signal	Protected pair
12	12		I/O12 Return	
38	38	13	I/O13 Signal	Protected pair
13	13		I/O13 Return	
39	39	14	I/O14 Signal	Protected pair
14	14		I/O14 Return	
40	40	15	I/O15 Signal	Protected pair
15	15		I/O15 Return	
41	41	16	I/O16 Signal	Protected pair
16	16		I/O16 Return	
42	42			
17	17			
43	43	17	XTRIG Signal	Protected pair
18	18		XTRIG Return	
44	44	18	STR Signal	Protected pair
19	19		STR Return	
45	45	19	XCLK Signal	Protected pair
20	20		XCLK Return	
46	46			
21	21			
47	47	20	STB Signal	Protected pair
22	22		STB Return	
48	48			
23	23			
49	49			
24	24			
50	50	21	Isolated +24V	On TB8301
25	25		Isolated 0V	

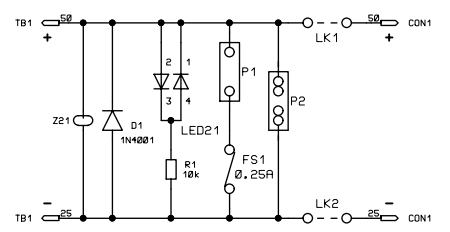
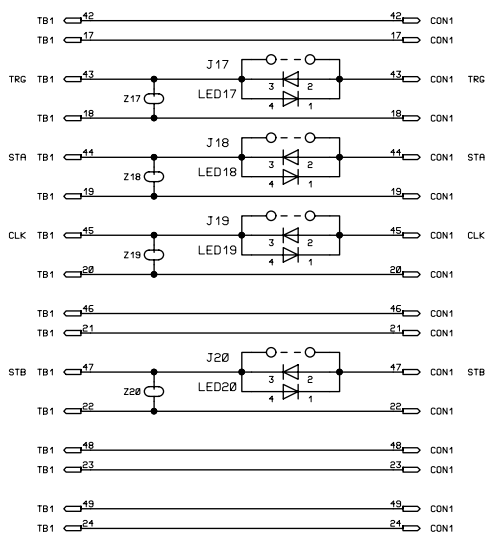
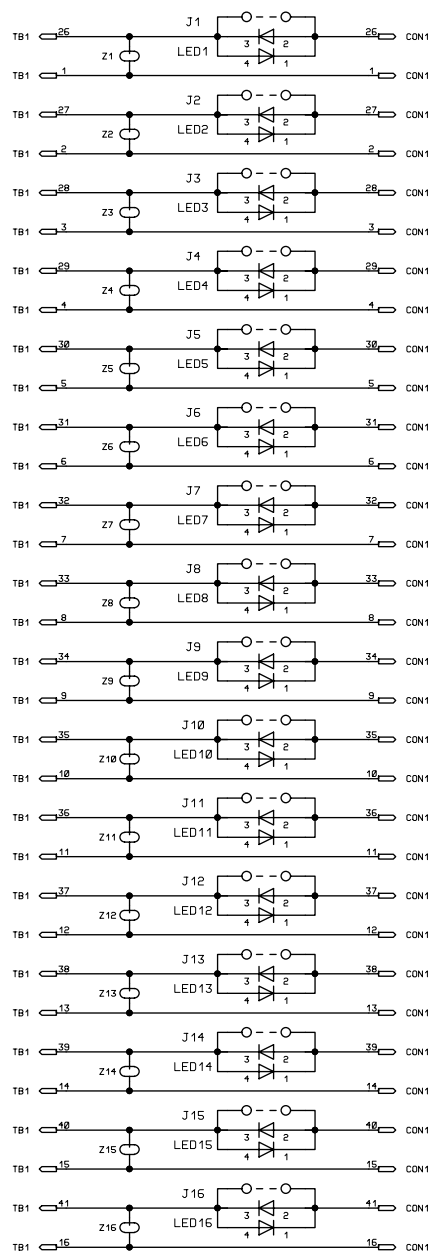

PROJECT: 8901-TD TERMINAL BOARD WITH LEDES  
 SHEET: 1 OF 1  
 DRAWING TITLE: CIRCUIT DIAGRAM 8901-TD  
 DRAWING NO.: 8901-TD/CCT/A/1/2.0  
 ISSUE: 2.0  
 DATE: 29-06-04  
 DRAWN BY: CGB  
 APPROVED:

